

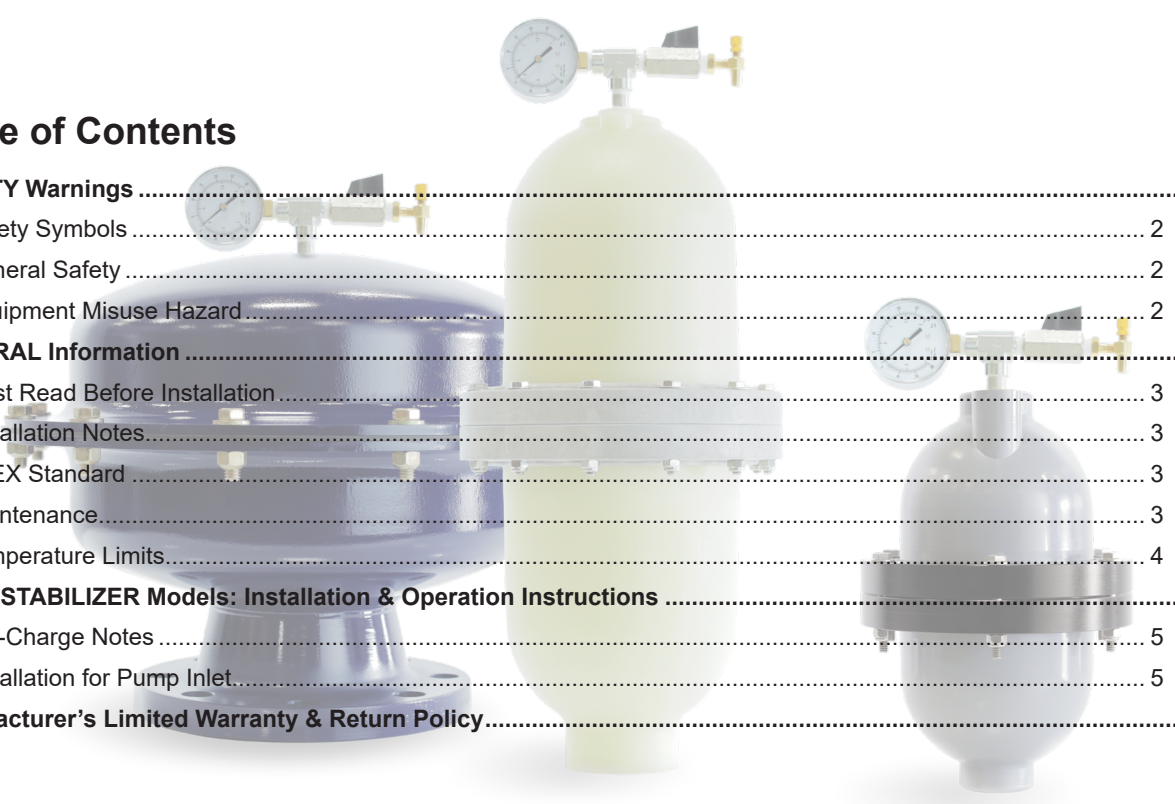

Installation and Operation Manual

Table of Contents



SAFETY Warnings	2
Safety Symbols	2
General Safety	2
Equipment Misuse Hazard	2
GENERAL Information	2
Must Read Before Installation	3
Installation Notes	3
ATEX Standard	3
Maintenance	3
Temperature Limits	4
INLET STABILIZER Models: Installation & Operation Instructions	5
Pre-Charge Notes	5
Installation for Pump Inlet	5
Manufacturer's Limited Warranty & Return Policy	6

All dampeners manufactured by BLACOH use pressure bodies made in the USA to ensure quality. Prior to shipment, each and every dampener is factory pressure tested to assure proper function and leak-free operation.

© 2024 Blacoh Fluid Controls, Inc. All rights reserved. Any unauthorized reproduction, distribution, alteration, or other use of this document, or any part hereof, without Blacoh Fluid Control, Inc.'s express written consent is prohibited.



Information in this document is subject to change without notice. This document is 6 pages. Any removal, omission, or modification of the document or any page or part hereof is prohibited. To ensure you have a complete and the most up-to-date document, please reference the latest version, available at <https://blacoh.com/literature.aspx?lang=0&cate=IO&item=103>. This document and the information herein is intended for informational purposes only and should not be relied upon for any particular purpose, application, project, equipment, work environment, or any other purpose other than for general information. Please read this entire document. If you do not fully understand the information provided in any part of this document, or if there are specific issues with your particular project or equipment, contact Blacoh Fluid Control, Inc. or its authorized representative.

SAFETY Warnings

Dampeners should only be installed, operated and repaired by experienced and trained professional mechanics. Read and observe all instructions and safety warnings in this Manual before installing, operating or repairing dampeners.

Safety Symbols

The following symbols indicate cautions, warnings and notes that must be observed for safe and satisfactory installation, operation and maintenance of dampener.

-  **WARNINGS** Danger of serious injury or death could occur if these warnings are ignored.
-  **CAUTIONS** Equipment damage, injury or death could occur if these cautions are not observed.
-  **NOTES** Special instructions for safe and satisfactory installation, operation and maintenance.

General Safety

- Observe all safety symbols in installation and operation instructions.
- The internal dampener pressure will equal the maximum fluid pressure of the system in which it is installed.
- **DO NOT** exceed maximum allowable working pressure (MAWP) specified on dampener serial tag or marked on dampener. If missing, **DO NOT** use dampener without consulting distributor or factory for maximum pressure rating.
- Always make sure safety shutoff valves, regulators, pressure relief valves, gauges, etc. are working properly before starting system or assembly.
- Verify dampener model received against purchase order and shipper.
- Before starting a system or assembly make certain the discharge point of the piping system is clear and safe, and all persons have been warned to stand clear.
- **DO NOT** put your face or body near dampener when the system or assembly is operating or dampener is pressurized.
- **DO NOT** operate a dampener that is leaking, damaged, corroded or otherwise unable to contain internal fluid, air or gas pressure.
- **DO NOT** pump incompatible fluids through dampener. Consult distributor or factory if you are not sure of the compatibility of system fluids with dampener materials.
- Dampeners are designed to operate with compressed air or clean dry Nitrogen **only**. Other compressed gases have not been tested and may be unsafe to use. **DO NOT USE OXYGEN.**
- Always shut off air supply, remove internal dampener pressure and shut dampener isolation valve before performing dampener maintenance or repair.
- Remove all pressure from dampener AND pumping system before disassembly, removal or maintenance.
- **Static spark can cause an explosion resulting in severe injury or death. Ground dampeners and pumping system when pumping flammable fluids or operating in flammable environments.**

Equipment Misuse Hazard

General Safety

DO NOT misuse dampener, including but not limited to over-pressurization, modification of parts, using incompatible chemicals, or operating with worn or damaged parts. **DO NOT** use any gases other than compressed air or clean dry Nitrogen to charge dampener. **DO NOT USE OXYGEN.** Any misuse could result in serious bodily injury, death, fire, explosion or property damage.

Over-Pressurization

Never exceed the maximum pressure rating for the dampener model being used. Maximum allowable working pressure (MAWP) is specified on dampener serial tag or marked on dampener. Maximum allowable working pressure (MAWP) is rated at 70°F (21°C) unless specified otherwise on unit.

Temperature Limits

DO NOT exceed the operating temperature limits for the body and/or elastomer materials being used. Excessive temperature will result in dampener failure. For temperature limits, refer to the "Temperature Limits" section of this Manual. Temperature limits are stated at zero psi/bar.

Installation and Startup Hazards

Install dampener before charging or pressurizing. **DO NOT** start system or assembly without first charging or pressurizing dampener. Failure to charge may result in damage to the bladder or bellows.

GENERAL Information

-  For safe and satisfactory operation of dampener read all safety warnings, caution statements and this complete Manual before installation, startup, operation or maintenance.

Temperature & Pressure Hazard

Temperature and pressure reduce the strength and chemical resistance of plastic, metal, elastomers and PTFE.

Charging / Pressurization

Charge or pressurize dampener with compressed air or clean dry Nitrogen only. **DO NOT USE OXYGEN.**





Dampener Bladder/Bellows Failure





Dampeners utilize a bladder or bellows to separate system fluid from the air supply or gas charge. When failure occurs, system fluid may be expelled from the air valve. Always perform preventive maintenance and replace bladder/bellows before excessive wear occurs. O-rings for PTFE bellows and gaskets for Stainless Steel metal bellows cannot be reused.

Maintenance Hazards





Never overtighten fasteners. This may cause leakage of system fluid and damage to dampener body. Bolts should not be reused as re-torquing reduces bolt strength. **After dampener maintenance or disassembly, use new fasteners and torque fasteners according to specification on dampener tag. If missing, consult distributor or factory for torque specifications.**

Must Read Before Installation

-  **DO NOT** use Oxygen to charge dampener. Use compressed air or clean dry Nitrogen only.
-  **DO NOT** exceed maximum allowable working pressure (MAWP) specified on dampener serial tag or marked on dampener.
-  Turn pump off and remove all pressure from system prior to dampener installation.
-  Always wear safety glasses and other appropriate safety equipment when installing, charging or repairing dampener.

-  **Danger of static spark!** Grounding precautions must be considered when dampener is used in flammable or explosive environments.
-  ATEX models must be grounded (earthed) before operation.
-  **DO NOT** operate a dampener that is leaking, damaged, corroded or otherwise unable to contain internal fluid, air or gas pressure.
-  Temperature, pressure and chemicals affect the strength of plastic, elastomer and metal components.
-  Many plastics lose strength rapidly as temperature increases. Consult factory if in doubt.

Installation Notes

-  Dampening of flow pulsations can only be effective if a minimum of 5 to 10 psi (0.4 to 0.7 bar) back pressure downstream of dampener is available. A BLACOH back pressure valve may be required downstream of dampener, except when dampener is used as an inlet stabilizer for the inlet side of the pump.
-  It is recommended that a BLACOH pressure relief valve be installed in all pump systems to ensure compliance with pressure limits on system equipment.
-  To avoid possible damage to bladder/bellows from a system pressure test:
 - Adjustable and Chargeable models** — charge dampener to 80% of the system test pressure prior to test.
 - Automatic model** — prior to test, dampener must be equipped with a constant source of compressed air with pressure equal to or greater than system test pressure.
 - Inlet Stabilizer model** — maximum pressure test 30 psi (2.0 bar), charge to 20 psi (1.3 bar) for system pressure test.
-  Install dampener as close to the pump discharge/inlet or quick closing valve as possible. Dampener installation should be no more than ten pipe diameters from pump discharge/inlet or quick closing valve.
-  It is recommended that an isolation valve be installed between the dampener and system piping.

ATEX Standard

-  Certain models made for the European market are intended for use in potentially explosive atmospheres and meet the requirements of ATEX directive 2014/34/EU. These models have the AT designation at the end of the part number, comply with ISO 80079-36, and have an ATEX rating of II 2GD Ex h IIB T4 Gb Db. AT models have a grounding lug and must be grounded (earthed) before operation.

Maintenance

-  **Remove all pressure from dampener AND pumping system before disassembly, removal or maintenance.**

Dampeners require very little maintenance. There is no need for lubrication with bladders or bellows.

Elastomeric bladder replacement should be part of a preventive maintenance program. Dampeners used in conjunction with diaphragm pumps should have the bladders replaced at least every second time the diaphragms in the pump are replaced. As with any pumping system, wear is dependent on many factors including material, temperature, chemicals, fluid abrasiveness and system design. This suggested maintenance program may need to be adjusted according to specific applications.

Periodic inspection of the dampener and fasteners should be conducted to visually check for signs of over-pressurization, fatigue, stress or corrosion. Body housings and fasteners must be replaced at first indication of deterioration.

-  **CAUTION! Replace nut and bolt fasteners at each reassembly with fasteners of equal grade/strength value. DO NOT reuse old nuts and bolts.**

After the initial torque of fasteners, bolts may lose strength when re-torqued. Failure to replace both nuts and bolts upon each vessel reassembly will void the product warranty given by the manufacturer and the manufacturer will have no liability whatsoever for any vessel failure or malfunction.

Where dampeners are used in corrosive environments, nut and bolt fasteners should be regularly inspected and replaced with nut and bolt fasteners of equal grade/strength value if corrosion is observed. Failure to conduct such regular inspections and replacement will void the product warranty given by the manufacturer and the manufacturer will have no liability whatsoever for any vessel failure or malfunction.

-  **IMPORTANT!** After maintenance or disassembly, use new fasteners and torque fasteners according to specification on dampener tag. If missing, consult distributor or factory for specifications.

-  **DO NOT** use dampener if the fasteners (nuts and bolts) are corroded. Check for fastener corrosion frequently, especially in atmospheres containing salt or corrosive chemicals, or if dampener leakage has occurred.

Temperature Limits

- ① Operating temperatures are based on the maximum temperature of the wetted dampener components only. Non-wetted dampener components may have a lower temperature limit. Temperature and certain chemicals may reduce the maximum allowable working pressure (MAWP) of the dampener.
- ① **CAUTION!** Plastic (non-metallic) body materials lose strength as temperature increases, which reduces the maximum pressure sustainable by the material. All plastic materials must have an appropriate derating factor applied when working at elevated temperatures above 73.4°F (23°C) to determine maximum allowable working pressure (MAWP).

Elastomer Materials	Temperature Limits		Applications
	°F	°C	
Aflas	0°F to +400°F	(-18°C to +204°C)	High temperature, petroleum based chemicals, strong acids and bases.
Buna-N	+10°F to +180°F	(-12°C to +82°C)	Good flex life; use with petroleum, solvents and oil-based fluids.
FDA Buna-N	+10°F to +180°F	(-12°C to +82°C)	FDA-approved food grade; similar characteristics of regular Buna-N.
EPDM	-60°F to +280°F	(-51°C to +138°C)	Use in extreme cold; good chemical resistance with ketones, caustics.
FDA EPDM	-50°F to +225°F	(-45°C to +107°C)	FDA-approved food grade; similar characteristics of regular EPDM.
Hypalon	-20°F to +275°F	(-29°C to +135°C)	Excellent abrasion resistance; good in aggressive acid applications.
Neoprene	0°F to +200°F	(-18°C to +93°C)	Good abrasion resistance and flex; use with moderate chemicals.
PTFE Diaphragm	+40°F to +220°F	(+4°C to +104°C)	Use with highly aggressive fluids.
PTFE Bellows	-20°F to +220°F	(-29°C to +104°C)	Exclusive bellows design with excellent flex life; use with highly aggressive fluids.
Santoprene	-20°F to +225°F	(-29°C to +107°C)	Excellent choice as a low cost alternative for PTFE in many applications.
FDA Silicone	-20°F to +300°F	(-29°C to +149°C)	FDA-approved food grade material; for use in food and pharmaceutical processing.
Viton®	-10°F to +350°F	(-23°C to +177°C)	Use with hot and aggressive fluids; good with aromatics, solvents, acids and oils.

Non-Metallic Body Materials	Temperature Limits		Applications
	°F	°C	
Acetal*	+32°F to +175°F	(0°C to +79°C)	Good flex life; low moisture sensitivity; high resistance to solvents and chemicals.
CPVC	+32°F to +180°F	(0°C to +82°C)	Chlorinated PVC (CPVC); Good general chemical resistance; loses strength as temperature rises.
Noryl	+32°F to +220°F	(0°C to +104°C)	Good resistance to acids and bases; good temperature stability.
Polypropylene*	+32°F to +175°F	(0°C to +79°C)	Good general purpose plastic; broad chemical compatibility at medium temperatures.
PTFE	+40°F to +220°F	(+4°C to +104°C)	Use with highly aggressive fluids, high temperatures.
PVC	+32°F to +140°F	(0°C to +60°C)	Good general chemical resistance; loses strength as temperature rises.
PVDF	+10°F to +200°F	(-12°C to +93°C)	Excellent resistance to most acids and bases; high temperatures.

* Conductive Acetal and Conductive Polypropylene available.

- ① Maximum allowable working pressure is reduced slightly for metal bellows at temperatures above 400°F (204°C). Apply an appropriate derating factor to determine maximum allowable working pressure (MAWP).

Metal Bellows	Temperature Limits		Applications
	°F	°C	
SS w/Gaskets*	-200°F to +800°F	(-129°C to +426°C)	Excellent for applications pumping frigid and molten fluids, outdoor applications in extreme temperatures, chemical applications where elastomers or PTFE would fail.

* Contact Blacoh for more information regarding temperatures below -200°F (-129°C).

[T22E11_031]

INLET STABILIZER Models: Installation & Operation Instructions

- ⓘ Inlet Stabilizer dampener models are for use on the inlet side of pumps only.
- ⓘ ATEX models must be grounded (earthed) before operation.
- ⚠ Turn pump off and remove all pressure from system prior to dampener installation.
- ⚠ Remove all pressure from dampener AND pumping system before disassembly, removal or maintenance.
- ⚠ Use compressed air to charge dampener. **DO NOT USE OXYGEN.**
- ⚠ **DO NOT exceed 30 psi (2 bar) maximum allowable working pressure (MAWP) to prevent damage to the compound pressure gauge. Check maximum pressure rating specified on dampener serial tag.** If missing, consult distributor or factory for specifications.
- ⚠ Always wear safety glasses and other appropriate safety equipment when installing, charging or repairing dampener.
- ⚠ Read and observe all safety warnings and instructions in this Manual before installation, operation or repair.
- ⚠ **IMPORTANT! After maintenance or disassembly, use new fasteners and torque fasteners according to specification on dampener tag.** If missing, consult distributor or factory for specifications.
- ⚠ Before performing a system pressure test, dampener must be charged with 80% of system test pressure, not to exceed 30 psi (2 bar), to avoid possible damage to bladder/bellows.
- ⚠ To properly adjust an Inlet Stabilizer dampener model, a compound pressure gauge must be installed in the pump inlet piping.

Pre-Charge Notes

Pre-charge pressure should be checked at least monthly as gas molecules will diffuse through bladders/bellows, the speed of which depends on the material, temperature and pressure. Checks must occur when no system pressure is present or inaccurate readings will be recorded. If temperature is above 72°F (22°C) and/or pressure is over 300 psi (20.6 bar), checks should be performed more frequently. **To prevent pre-charge loss through the fill valve, always replace the fill valve cap after charging.** A proper gas charge is the key to dampener effectiveness and bladder/bellows life.

Installation for Pump Inlet

Step 1 Installation Position

Install the dampener as close to the pump inlet as possible and after any upstream equipment such as risers, valves, elbows, meters or filters. Dampener installation should be no more than ten pipe diameters from pump inlet. If using a flexible connector on the inlet side of the pump between the system piping and pump, the dampener should be installed on a tee at the pump inlet manifold. The flexible connector should be attached to the dampener's tee and system piping (see Figure 1). A compound pressure gauge should be installed upstream of the dampener to aid in proper dampener adjustment.

Step 2 Charging and Startup (see Pre-Charge Notes)

Inlet Stabilizer dampener models do not require a permanent air line connection.

A. Suction Lift/Negative Inlet Pressure Application: Follow the steps below to make required adjustments. Pump must be running before adjusting dampener.

1. Close the ball valve (Part ② on Figure 2).
2. Turn the pump on and observe the changes in pressure on the compound pressure gauge at the pump inlet (Figure 1).
3. Attach a compressed air line with an air chuck (not included) to the venturi valve (Part ① on Figure 2).
4. Open the ball valve. As compressed air flows through the venturi valve, observe the compound pressure gauge (Part ③ on Figure 2) on the dampener. As soon as the gauge reads 5" to 6" Hg vacuum (-0.17 to 0.20 bar), close the ball valve. If the ball valve is left open too long while adding compressed air pressure to the venturi valve, the bladder/bellows will be drawn all the way up to the top of the dampener. This will eliminate the vacuum pull of the bladder/bellows making the dampener less effective. If this occurs, turn the pump off, add 10 psi (0.7 bar) pressure to the dampener to push the bladder/bellows back down, and repeat steps 1 through 4.
5. The vacuum observed on the dampener's compound pressure gauge (Part ③ on Figure 2) should read approximately the same as that on the inlet pipe's compound gauge, and needle fluctuations should now be minimal. The vacuum may need to be adjusted up or down to obtain minimum movement on the inlet pipe's compound gauge.

B. Positive Inlet Pressure: Pre-charge the dampener with 50%, not to exceed 30 psi (2 bar), of the static system pressure realized at the pump inlet. Start the pump to generate working pressure. Minor pressure adjustments may be required. Allow the system to respond to each adjustment (this may take a minute or two) before making further adjustments. Follow the steps below to make required adjustments.

1. Close the ball valve (Part ② on Figure 2).
2. Attach a compressed air line with an air chuck (not included) to the venturi valve (Part ① on Figure 2).
3. Open the ball valve.

4. With a finger partially covering the exhaust air from the bottom of the venturi valve, watch the compound pressure gauge on the dampener (Part ③ on Figure 2) until it reaches 50%, not to exceed 30 psi (2 bar), of static inlet pressure.
5. Close the ball valve.



To prevent damage to the compound pressure gauge, DO NOT exceed 30 psi (2 bar) maximum allowable working pressure (MAWP).

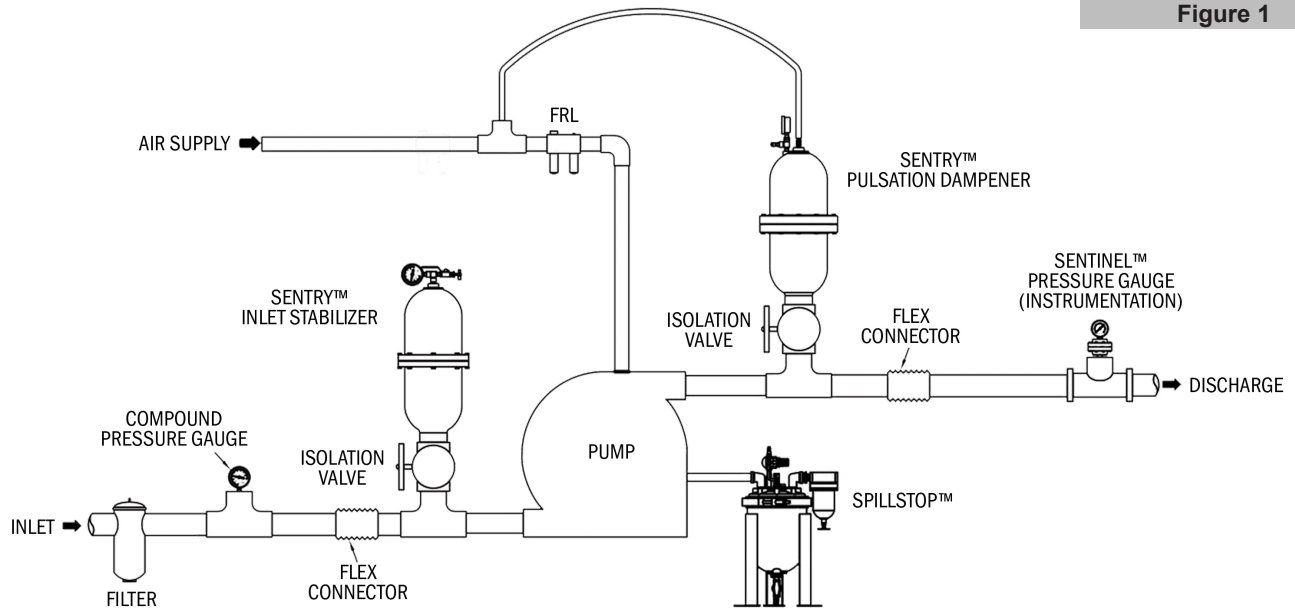

Figure 1

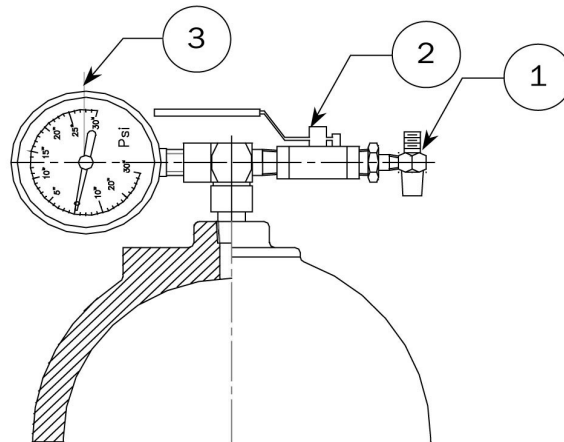

Figure 2

Manufacturer's Limited Warranty & Return Policy

Details regarding warranty and return policy are available on Blacoh's website at Blacoh.com

M14E11_093

BLACOH[™]
INDUSTRIES

PROUDLY MANUFACTURED IN THE USA
601 Columbia Ave, Bldg D, Riverside, CA 92507 USA
951.342.3100 | Sales@Blacoh.com | Blacoh.com